

USER'S INFORMATION MANUAL

MODELS: MG9S SERIES

33" Multi-position Gas Furnaces (Manufactured Housing or Modular Home Applications)



TABLE OF CONTENTS

SAFETY	1	Removing Filters For Manufactured (Mobile) Home And Modular Home Installations Without A Return Air Duct System And Plenum	4
INSTRUCTIONS FOR EXAMINING THE FURNACE INSTALLATION	2	BLOWER CARE	5
START-UP AND SHUTDOWN INSTRUCTIONS	2	MOTOR LUBRICATION	5
HOW YOUR GAS FURNACE WORKS	3	SERVICE INFORMATION	5
OPERATING INSTRUCTIONS	3	TROUBLESHOOTING PROBLEMS	5
TO TURN OFF THE APPLIANCE	3	FURNACE CONTROL DIAGNOSTICS	5
FURNACE MAINTENANCE - USER INFORMATION	4	FURNACE MAINTENANCE - DEALER/CONTACTOR	5
EXTERNAL AIR FILTERS	4	REPLACEMENT PARTS LIST	5
How to Clean your Filter	4	WIRING DIAGRAM	5
Removing Filters For Manufactured (Mobile) Home And Modular Home Installations Using A Return Air Duct System And Plenum	4	LIMITED WARRANTY	7

CONTACT INFORMATION FOR USA		CONTACT INFORMATION FOR CANADA
<ul style="list-style-type: none"> Contact us by mail: DISTRIBUTED BY: Style Crest Inc. Drawer A Fremont, OH 43420 	<ul style="list-style-type: none"> Manufacturer: Johnson Controls, Unitary Products 	<ul style="list-style-type: none"> Go to website at www.york.com click on "contact", then click on "contact form" and follow the instructions. Contact us by mail: Johnson Controls Unitary Products Consumer Relations 5005 York Drive Norman, OK 73069

The manufacturer recommends that the user read all sections of this manual and keep the manual for future reference.

SECTION I: SAFETY

⚠ WARNING

FIRE OR EXPLOSION HAZARD - Failure to follow safety warnings exactly could result in serious injury, death, or property damage.

- **Do not store or use gasoline or other flammable vapors and liquids in the vicinity of this or any other appliance.**
- **WHAT TO DO IF YOU SMELL GAS:**
 - Do not try to light any appliance.
 - Do not touch any electrical switch; do not use any phone (including cell phone) in your building.
 - Leave the building immediately.
 - Immediately call your gas supplier from a neighbor's phone. Follow the gas supplier's instructions.
 - If you cannot reach your gas supplier, call the fire department.
- Installation and service must be performed by a qualified installer, service agency or the gas supplier.

 This is a safety alert symbol. When you see this symbol on labels or in manuals, be alert to the potential for personal injury.

Understand and pay particular attention to the signal words **DANGER**, **WARNING**, or **CAUTION**.

DANGER indicates an **imminently** hazardous situation, which, if not avoided, **will result in death or serious injury**.

WARNING indicates a **potentially** hazardous situation, which, if not avoided, **could result in death or serious injury**.

CAUTION indicates a potentially hazardous situation, which, if not avoided **may result in minor or moderate injury**. It is also used to alert against unsafe practices and hazards involving only property damage.

- The furnace area must be kept clear and free of combustible materials, gasoline and other flammable vapors and liquids.
- Insulating materials may be combustible. The furnace must be kept free and clear of insulating materials. The furnace area must be examined when installed in an attic or other insulated space or when insulation is added to be sure that the insulation material has been kept away from the furnace.
- The furnace needs air for combustion in order to operate properly and safely. Do not block or obstruct air openings on the furnace, air openings to the area where the furnace is installed, or spaces around the furnace.
- Follow the instructions exactly as shown on the OPERATING INSTRUCTION LABEL on the furnace or the "START-UP AND SHUTDOWN INSTRUCTIONS" section of this manual when lighting the furnace or turning the furnace off.
- Should the gas supply fail to shut off or if overheating occurs, shut off the gas valve to the furnace before shutting off the electrical supply.
- Do not use this furnace if any part has been under water. A flood-damaged furnace is extremely dangerous. Attempts to use the furnace can result in fire or explosion. A qualified service agency should be contacted to inspect the furnace and replace all gas controls, control system parts, electrical parts that have been wet or the furnace if deemed necessary.

7. NEVER . . .Store flammable materials of any kind near your furnace. Gasoline, solvents, and other volatile liquids should be stored only in approved containers outside your home. These materials vaporize easily and are extremely dangerous.
8. NEVER . . .Store cleaning materials near your furnace. Materials such as bleaches, detergents, powdered cleansers, etc., can cause corrosion of the heat exchangers.
9. NEVER . . . Use the area around your furnace as a storage area for items which could block the normal flow of air. This flow of air is required for ventilation of the various furnace components.

⚠ WARNING

FIRE OR EXPLOSION HAZARD

This furnace is designed and approved for use with Natural Gas and (LP) Propane Gas ONLY. DO NOT BURN ANY LIQUID FUEL OR SOLID FUEL IN THIS FURNACE.

Burning any unapproved fuel will result in damage to the furnace heat exchanger, which could result in Fire, Personal Injury, and/or Property Damage.

SECTION II: INSTRUCTIONS FOR EXAMINING THE FURNACE INSTALLATION

It is the owner's responsibility to ensure that an annual inspection of the entire heating portion of the unit is made by a qualified service agency. Examine the furnace as outlined below in steps "1 - 8" before each heating season. Use Figure 1 for visual reference.

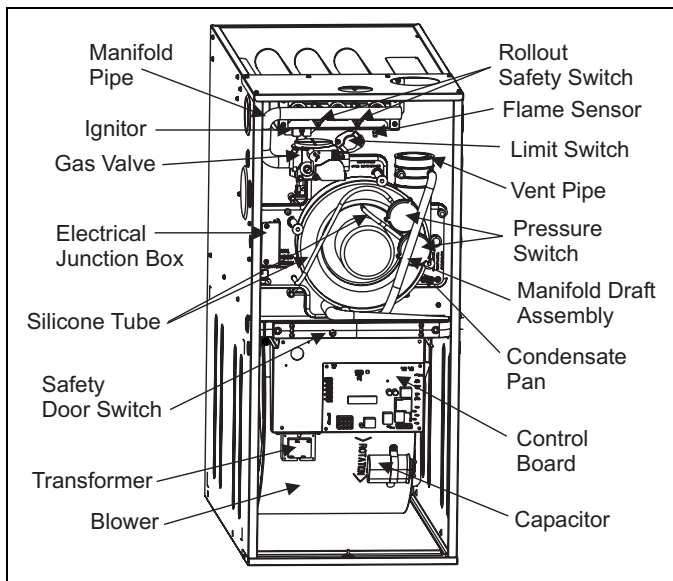

FIGURE 1: Component Location - 95% Single Stage Models

1. Examine the heat exchanger, vent pipe, combustion air passages, vent connectors and chimney to be sure they are clear and free of obstructions.
2. Examine the vent pipe making sure it is firmly in place, that it slopes slightly upward and is physically sound without holes and all of the connections are secure.

3. Examine return connections

- For Modular Homes:

- a. If the furnace has a return air duct, examine the return air duct connections to make sure they are physically sound, sealed to the furnace casing, and the ducts terminate outside the space containing the furnace.
- b. If the furnace does not have a return air duct, examine the return air filter rack connections to make sure they are physically sound, sealed to the furnace casing.

- For Manufactured (Mobile) Homes:

- a. Examine the return air filter rack connections to make sure they are physically sound, sealed to the furnace casing.

4. Examine the furnace casing making sure the physical support is sound without sagging, cracks or gaps. Examine the furnace base making sure it is physically sound without cracks, gaps or sagging and has a good seal.

5. Examine the furnace casing for obvious signs of deterioration.

6. Examine the burner flames to make sure they are in good adjustment. Refer to the pictorial sketch shown in Figure 2 as a comparison to the actual flame.

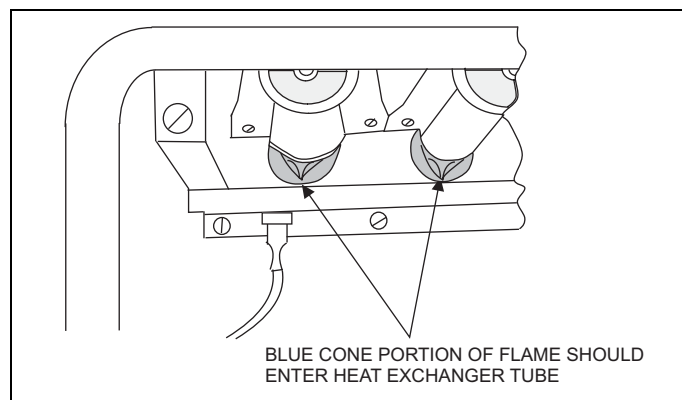

FIGURE 2: Burner Flame Drawing (Upflow Configuration Shown)

7. Examine and replace external air filters as needed to make sure they are not blocked, and proper airflow is provided to the furnace.
8. Examine any installed accessories or system components such as evaporator coils to insure proper operation, drainage of condensate, and that there is no water leakage or damage to the furnace or any components.

SECTION III: START-UP AND SHUTDOWN INSTRUCTIONS

Read the Instructions Below Before Trying to Start the Furnace!

⚠ WARNING

If you do not follow these instructions exactly, a fire or explosion may result causing property damage, personal injury, and/or loss of life.

HOW YOUR GAS FURNACE WORKS

Your furnace is a very easy appliance to take for granted. Season after season, it sits there in your home, keeping you warm and comfortable. For this reason, you may never have given much thought to the way your furnace operates. In order to get the safest and most efficient operation from your furnace, you should understand how your furnace does its job.

When you set your thermostat to provide more heat in your home, you are starting the heating cycle of the furnace. First, the inducer motor starts to purge the heat exchanger of any remaining gases. Next, the hot surface ignitor glows and after a warm-up period the gas valve opens and ignition occurs. A short time later, the blower starts and distributes the warm air throughout the home. When the temperature setting on your thermostat is reached, the gas valve closes, the main burners are turned off, and the blower continues to run until the remaining warm air in the system is distributed. When the blower stops, the heating cycle has ended.

1. This appliance does not have a pilot. It is equipped with an ignition device which automatically lights the burner. Do not try to light the burner by hand.
2. BEFORE OPERATING; smell all around the appliance area for gas. Be sure to smell next to the floor because some gas is heavier than air and will settle on the floor.
3. Use only your hand to push the gas control switch to the "on" position. Never use tools. If the switch will not operate by hand, don't try to repair it, call a qualified service technician. Force or attempted repair may result in a fire or explosion.
4. Do not use this appliance if any part has been under water. Immediately call a qualified service technician to inspect the appliance and to replace any part of the control system and any gas control, which has been under water.

OPERATING INSTRUCTIONS

1. STOP! Read the safety information above for your protection.
2. Set the thermostat to the lowest setting in the heat mode.
3. Turn off all electric power to the appliance.
4. Remove furnace burner access panel/door.
5. Move gas control switch to the "OFF" position. Do not force. See Figure 3.

6. Wait five (5) minutes to clear out any gas. If you then smell gas, STOP! Follow "B" in the safety information above. If you don't smell gas, go to next step.
7. Move gas control switch to the "ON" position. Do not force. See Figure 3.
8. Replace furnace burner access panel/door.
9. Turn on all electric power to the appliance.
10. Set thermostat to the desired setting. Burner will light, which may take 30-60 seconds.
11. After three (3) trials for ignition, if the appliance will not operate follow the instructions, "TO TURN OFF THE APPLIANCE" and call your service technician or gas supplier.

TO TURN OFF THE APPLIANCE

1. Set the thermostat to lowest setting in heating mode.
2. Turn off all electric power to the appliance if service is to be performed.
3. Remove furnace burner access panel/door.
4. Move gas control switch to the "OFF" position. See Figure 3.
5. Replace furnace burner access panel/door.

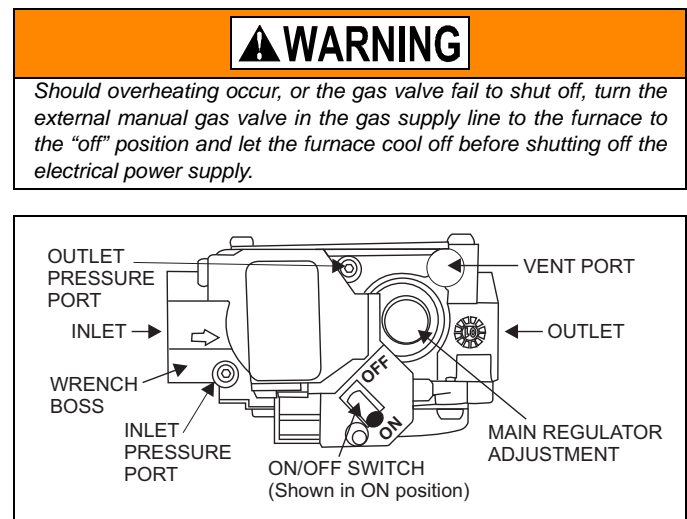

FIGURE 3: Single Stage Gas Valve

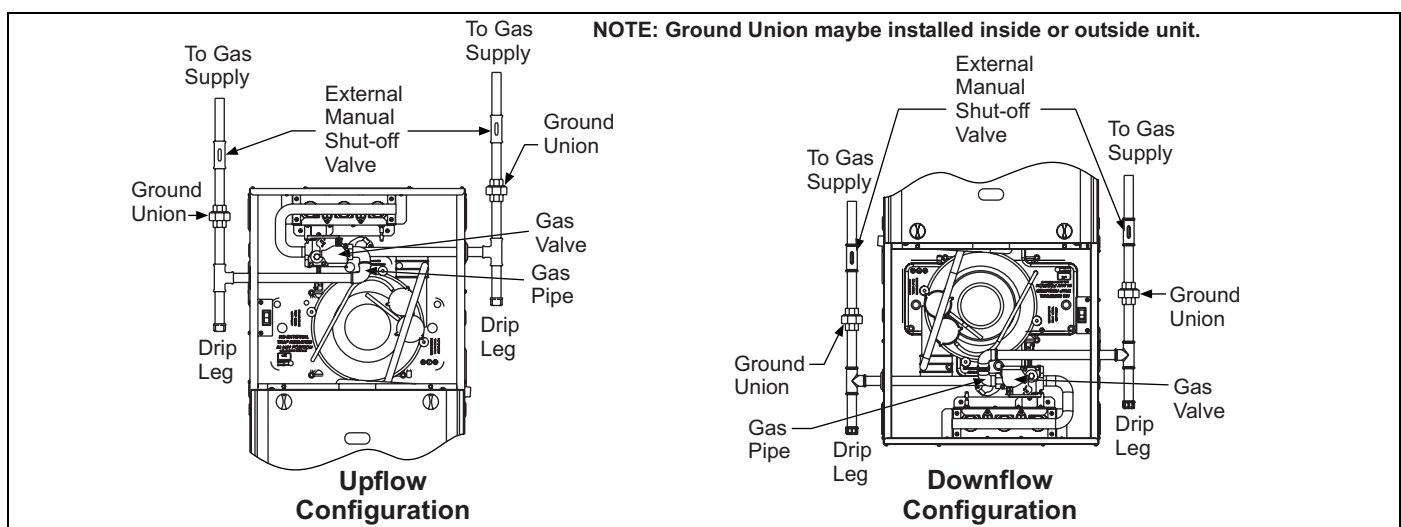

FIGURE 4: Upflow/Downflow Gas Piping

SECTION IV: FURNACE MAINTENANCE - USER INFORMATION

WARNING

Before proceeding, be sure the area is well ventilated. Turn the thermostat OFF. If the blower is running, wait until it stops automatically. Turn OFF the gas and electrical power supplies to the furnace. Check all metal parts and surfaces to be sure they have cooled to room temperature before you begin.

EXTERNAL AIR FILTERS

Filters used with this furnace must be installed external to the furnace casing. **DO NOT attempt to install filters inside the furnace cabinet.**

Some installations may have the air filter in a rack attached to the casing of the furnace or placed in the return air duct. If the filter location or replacement process is not obvious, contact your installer or service technician for assistance.

Every time the external air filters are changed the following items should be visually inspected:

- Check combustion air and vent pipe for blockage or leakage.
- Check all components to be sure they are in good condition and that there are no obvious signs of deterioration.
- Check the drain lines to make sure there are no cracks or leaks.
- Check for dirt or lint on any surfaces or on components. Do not try to clean any of the surfaces or components. Cleaning of the furnace and its components must be done by a qualified service professional.

If during the inspection of your furnace, you find any of the following conditions:

- Excessive amounts of dust and lint on components.
- Damaged or deteriorated components or surfaces.
- Leaks or blockage in the vent pipe passages.
- Water on any surface inside or outside of the furnace.

Do not operate the furnace, call a certified dealer or servicing contractor to check or clean your furnace, or for more information if you have questions about the operation of your furnace.

If all components appear to be in good operating condition, replace the furnace access panels/doors. Turn ON the gas and electrical power supplies to the furnace, and set thermostat to the desired temperature.

How to Clean your Filter

High-velocity filters may be cleaned with a vacuum cleaner or washed with a garden hose. Be sure to shake off excess water and allow filter to completely dry before re-installing the filter.

Replace throw away filter(s) with the same size new filter(s). Throw away filter(s) may be replaced with cleanable filter(s) at this time.

Removing Filters For Manufactured (Mobile) Home And Modular Home Installations Using A Return Air Duct System And Plenum

Modular Home downflow furnaces requiring a return duct system by Local, State, or Regional Codes will have the filters located on the top of the furnace in an external filter rack located inside the return air plenum as shown in Figure 5. To check, clean or replace the air filters you should:

1. Follow the instructions to turn off the appliance before servicing.

2. Filters that are installed in the return air plenum above the blower assembly and are located in an "V" frame assembly that supports the filters as shown in Figure 5.
3. To remove the filters you must remove the screws that are securing the access panels on the return air plenum and remove the access panels.
4. Lift the filters lightly and remove them.
5. If the filters are the throw away type you must replace the filters with filters that are the same size as the filters you removed. If you want to replace the throwaway air filters with permanent washable filters you can do so at this time.
6. If the filters are washable, follow the instructions "HOW TO CLEAN YOUR FURNACE'S FILTER".
7. To reinstall the air filters reverse steps 1 – 6 above.
8. To place the furnace back in operation follow the operating instructions to place appliance in operation.

Removing Filters For Manufactured (Mobile) Home And Modular Home Installations Without A Return Air Duct System And Plenum

Manufactured (Mobile) Home downflow furnaces and modular home furnaces not requiring a return duct system by Local, State, or Regional codes will have the filters located on the top of the furnace in an external filter rack. To check, clean or replace the air filters you should:

1. Follow the instructions to turn off the appliance before servicing
2. Filters that are installed on the top of the furnace above the blower assembly and are located in an "A" frame assembly that supports the filters as shown in Figure 5.
3. To remove the filters just slide them out of the assembly. You may have to bend the filters to slide them around the combustion air and the vent pipes.
4. If the filters are the throw away type you must replace the filters with filters that are the same size as the filters you removed. If you want to replace the throwaway air filters with permanent washable filters you can do so at this time.
5. If the filters are washable, follow the instructions "HOW TO CLEAN YOUR FILTER".
6. To reinstall the air filters reverse steps 1 – 4 above.
7. To place the furnace back in operation follow the operating instructions to place appliance in operation.

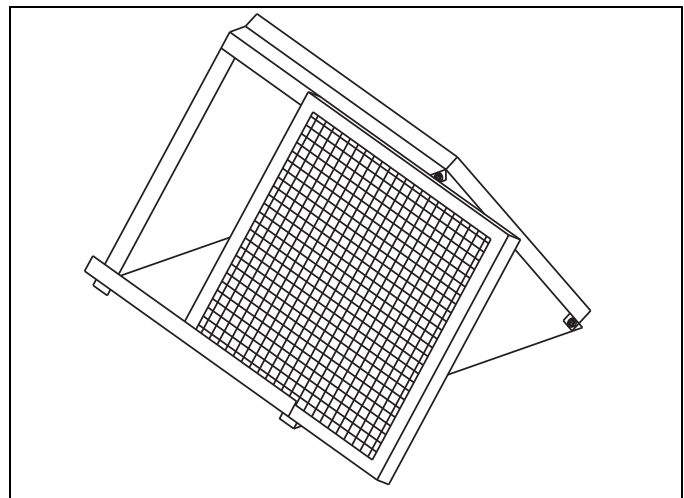

FIGURE 5: Mobile Home Filter Frame

BLOWER CARE

Even with good filters properly in place, blower wheels and motors will become dust laden after months of operation. The entire blower assembly should be inspected annually. This service must be performed by a qualified service agency.

NOTICE

The spring-loaded safety cut-off switch, mounted at the blower deck will automatically cut off the electrical power supply to the furnace when the furnace blower access panel/door is removed. As a safety precaution, all electrical power and the gas supply to the furnace should be turned off before servicing.

WARNING

Make sure you DO NOT move the clip on weight on the indoor fan wheel when cleaning the wheel. This weight is used to balance the wheel. Moving the weight will cause the fan wheel to vibrate.

MOTOR LUBRICATION

The motors in these furnaces are permanently lubricated, and do not require periodic oiling.

SECTION V: SERVICE INFORMATION

TROUBLESHOOTING PROBLEMS

If your furnace is not operating correctly, the following visual checks should be made before contacting your local contractor, dealer, or service provider.

1. Check that electrical power to the furnace is turned on.
2. Check that the manual gas shut-off valve in the gas piping supply is turned to the ON position. Refer to Figure 3.
3. Check that the ON/OFF switch on the gas valve is turned to the ON position. Refer to Figure 3.
4. Check that the furnace blower access panel/door is correctly positioned. The electrical power supply will be cut off if this door is removed.

FURNACE CONTROL DIAGNOSTICS

The furnace has built-in, self-diagnostic capability. If a system problem occurs, a blinking LED shows a fault code. The LED can flash red, green or amber to indicate various conditions. It is located behind a clear view port in the blower compartment door.

The control continuously monitors its own operation and the operation of the system. If a failure occurs, the LED will indicate the failure code. If the failure is internal to the control, the light will stay on continuously. In this case, the entire control should be replaced, as the control is not field repairable.

Flash sequence codes 1 through 10 are as follows: LED will turn "on" for 1/4 second and "off" for 1/4 second. This pattern will be repeated the number of times equal to the code. For example, six "on" flashes equals a number 6 fault code. All flash code sequences are broken by a 2 second "off" period.

SLOW GREEN FLASH: Normal operation.

DOUBLE AMBER FLASH: Normal heating operation - Modulating Furnace Models Only

SLOW AMBER FLASH: Normal operation with call for heat.

RAPID RED FLASHES: There is a problem with the operation of this furnace. Contact your local dealer, contractor or service provider.

FURNACE MAINTENANCE - DEALER/CONTACTOR

The furnace should be cleaned and adjusted by a certified dealer or qualified service contractor once a year or before the start of every heating season. The following items must be cleaned and serviced or replaced if there are signs of deterioration.

1. The vent terminal.
2. The furnace vent and combustion air intake passageways. Should it be necessary to service the vent/air intake system, the manufacturer recommends this service be conducted by a qualified service agency. The operation of this appliance requires the reassembly and resealing of the vent/air intake system.
3. The furnace burners, ignitor and flame sensor.
4. The condensate collection and disposal system. If any disassembly of components containing flue or vent gases is required, a qualified service agency must perform the service.
5. Heat exchanger assembly.
6. Induced draft motor assembly.

REPLACEMENT PARTS LIST

All components, assemblies, accessories, and replacement parts for this furnace are available through qualified service agencies. It is not recommended that the user purchase, install, or replace any components of this furnace. Contact your local contactor, dealer, or service provider for additional information.

WIRING DIAGRAM

The unit wiring diagram may be found on the inside of one of the access panels on the furnace. It is intended for reference only. If service is required, contact your local contactor, dealer, or service provider.

NOTES

Limited Warranty

Manufactured Housing Furnaces

WARRANTY TERMS: Johnson Controls Unitary Products (hereinafter "Company") warrants this product to be free from defects in factory workmanship and material under normal use and service and will, at its option, repair or replace any parts, without charge, subject to the exclusions below, that prove to have such defects according to the terms outlined in this warranty. Company reserves the right, at its sole discretion, to provide a replacement unit in the place of repair parts, in which case the warranty period for the replacement unit is limited to the remainder of the original warranty period. Alternatively, Company may, at its option, extend a replacement allowance to be applied toward the purchase of a new unit marketed by Company. The exact amount of the allowance will be determined at the discretion of Company, based upon current market conditions, but in no case shall this allowance exceed thirty (30) percent of the original consumer purchase price of the unit excluding such items as ductwork, wiring, piping, and installation costs. The warranty period for repair or replacement parts or unit provided hereunder shall not extend beyond the warranty period stated below. Company shall have no responsibility hereunder for installation, shipping, handling, or other charges except as specifically provided herein.

This warranty covers only the equipment described by the Product Model Number and Unit Serial Number on the equipment or listed on the Warranty Registration Card, and applies only to products installed in the United States, Canada, or Puerto Rico. Tampering, altering, defacing, or removing the product serial number will serve to void this warranty. This warranty extends only to the original consumer purchaser and is nontransferable. For this warranty to apply, the product must be installed according to Company recommendations and specifications, and in accordance with all local, state, and national codes; and the product or residence must not be removed from its place of original installation. This warranty does not apply to any unit sold over the Internet, by telephone or other electronic means unless the dealer that buys or sells a unit over the Internet, by telephone or other electronic means also installs the unit. In the absence of a recorded Warranty Registration Card, the warranty period will begin upon product shipment from Company. If you are unaware of the date the warranty became effective, contact Company at (877) 874-7378 or visit www.upgproductregistration.com.

ADDITIONAL CONDITIONS FOR HEAT EXCHANGER WARRANTY: This warranty shall cover the heat exchanger (primary and/or secondary, if applicable) only if:

1. The product has not been operated with an input rate in excess of the rating plate attached to the product.
2. The product has not been allowed to operate without the use of the proper automatic limit control on the maximum warm air temperature and/or without adequate circulation.
3. The product is installed so that the combustion air is not contaminated by compounds of chlorine, fluorine, or other damaging chemicals (or vapors).
4. The product is installed such that the heat exchangers are not exposed to return air temperatures below stated ratings.

FOR PRODUCT REGISTRATION: For your benefit and protection, register your product with Company promptly after installation. This will initiate the warranty period and allow us to contact you, should it become necessary. You can register your product online at www.upgproductregistration.com or by returning the Warranty Registration Card on the back page of this packet.

Product Model Number: _____ Installation Date: _____

Unit Serial Number: _____ Installing Dealer: _____

FOR WARRANTY SERVICE OR REPAIR: Consult the Authorized Service Center List packed with the unit installed in the manufactured home or contact your installing or servicing dealer. The Authorized Service Center List is also available online at <http://www.stylecrestinc.com/manufactured-housing-products/hvac-service-documents/>

Or, look in the Yellow Pages of the telephone book under Mobile Homes or Manufactured Housing Repair and Service for the name and telephone number of the nearest authorized manufactured housing service center. If local authorized service cannot be obtained, or you are unable to contact your installing dealer, contact the authorized distributor in your area. If you are unable to contact an authorized servicer, please contact StyleCrest Inc., at 1-800-231-4822. If there is no distributor in your area, and you cannot obtain proper service under the terms of the warranty, please write: Johnson Controls Unitary Products, Consumer Relations, 5005 York Drive, Norman, OK 73069.

WARRANTY PERIOD: The warranty period in years, depending on the part, is as shown in the chart below.

FURNACE MODELS			
Furnace Model	Heat Exchanger	Parts Coverage	Labor and Trip Coverage*
MG9S	15 years	2 years	1 year

NOTES:

*The warranty period for any replacement heat exchanger or part provided here under shall not extend beyond the warranty period stated above. The heat exchanger warranty is on a parts only basis: no labor, freight or other service charges are allowed.

The warranty period will begin on the purchase date of the residence when the product is installed as original equipment, or the installation date when installed in a residence previously purchased by the consumer.

MAINTENANCE: Company strongly recommends regular periodic preventive maintenance on this equipment. The person most familiar with the equipment in your HVAC system is a Participating Dealer. The Participating Dealer can ensure that your maintenance program meets the "Company Warranty" conditions, maximize the equipment efficiency, and service your unit within the mandated guidelines with regard to unlawful discharge of refrigerants into the atmosphere.

EXCLUSIONS: This warranty does not cover any:

1. Shipping, labor, or material charges or damages resulting from transportation, installation, or servicing.
2. Damage or repairs required as a consequence of mishandling, faulty installation, misapplication, abuse, improper servicing, unauthorized alteration, or improper operation.
3. Damages or failure to start resulting from improper voltage conditions, blown fuses, open circuit breakers, or other inadequacy or interruption of electrical service or fuel supply.
4. Fuses, either internal or external to the product.
5. Labor or other costs incurred for diagnosing, repairing, removing, installing, shipping, servicing, or handling of either defective parts or replacement parts.
6. Products removed from their original location for reinstallation purposes.
7. Damages resulting from accident, abuse, fire, flood, alteration, or acts of God.
8. Damages resulting from use of the product in a corrosive atmosphere.
9. Normal maintenance, or damages resulting from failure to perform normal maintenance, as outlined in the installation and servicing instructions or owner's manual.
10. Cleaning or replacement of filters, nozzles, or orifices.
11. Damages resulting from operation with inadequate supply of air or water; Damages resulting from failure to properly and regularly clean air and/or water side of condenser and evaporator.
12. Damages resulting from: (I) freezing of condenser water or condensate; (II) inadequate or interrupted water supply; (III) use of corrosive water; (IV) fouling or restriction of the water circuit by foreign material or like causes.
13. Damages caused by improper parts, components or accessories not suitable for use in or with the unit. For a list of parts that are known to be compatible please reference the equipment renewal parts list, contact a Participating Dealer for assistance, or call 1-877-874-7378.
14. Electricity or fuel costs, or increases in fuel or electric costs, for any reason including additional or unusual use of supplemental electric heat.

This warranty is in lieu of all other express warranties. All implied warranties, including the implied warranty of merchantability and fitness for a particular purpose are limited in duration to the actual warranty period applicable to the part. Some states do not allow the disclaimer of implied warranties, so the above disclaimer may not apply to you. In addition, some states do not allow limitations on how long an implied warranty lasts, so the above limitation may not apply to you. In no event, whether as a result of breach of warranty or contract, tort (including negligence), strict liability, or otherwise, shall Company be liable for special, incidental, or consequential damages or expenses, including but not limited to loss of use of the equipment or associated equipment, lost revenues or profits, cost of substitute equipment, or cost of fuel or electricity.

The above limitations shall inure to the benefit of Company's suppliers and subcontractors. The above limitation on consequential damages shall not apply to injuries to persons in the case of consumer goods. Company does not assume, or authorize any other person to assume for Company, any other liability for the sale of this product. Some states do not allow the exclusion or limitation of incidental or consequential damages, so the above limitation may not apply to you. This warranty gives you specific legal rights. You may also have other rights which vary from state to state.