

# STAIR-NOSING PROFILES



## INNOVATIVE SOLUTIONS FOR CERAMIC AND STONE TILE

FINISHING, EDGE PROTECTION, VISUAL ENHANCEMENT, AND SLIP-RESISTANCE

Ceramic and stone tiles are brittle materials whose exposed edges are prone to cracking and chipping when left unprotected. Tiled stair edges that do not utilize appropriate trim pieces are left vulnerable to chipping and breaking and can create a slip hazard, especially in exterior applications. Schluter® stair-nosing profiles protect exposed tile edges and improve safety on tiled stairways by providing slip-resistant wear surfaces and increased visibility in both residential and commercial applications.

### Application and Function

#### Residential Applications

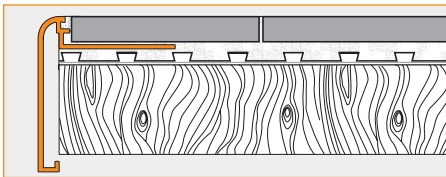

**2.8 Schluter®-ROND-STEP** is a finishing and edging profile for ceramic tile and natural stone installations on stairs and countertops. The profile features a trapezoid-perforated anchoring leg, which is secured in the mortar bond coat beneath the tile. The top of the profile features a symmetrically rounded edge with 1/4" (6 mm) radius, which matches the Schluter®-ROND-STEP profile, while the vertical leg of the profile hides the exposed edge of the sub-assembly. In addition, the profile effectively protects tiles in the edge area from mechanical and impact stresses. The integrated joint spacer establishes a defined joint cavity between the tile and the profile. Schluter®-ROND-STEP is suitable for residential applications, e.g., stairs not exposed to heavy traffic, and countertops. Schluter®-ROND-STEP is available in two vertical leg lengths, 1-1/2" (39 mm) and 2-1/4" (57 mm), to cover the

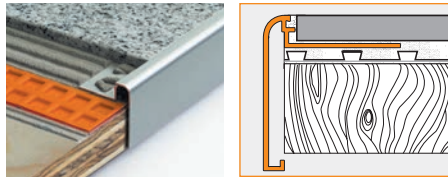

2.8 Schluter®-ROND-STEP

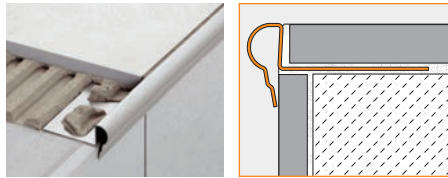

3.4 Schluter®-TREP-FL

edge of the sub-assembly. The profile is available in anodized aluminum with various finishes to allow for decorative design and interesting accents. Matching corners for the RONDEC-STEP are available.

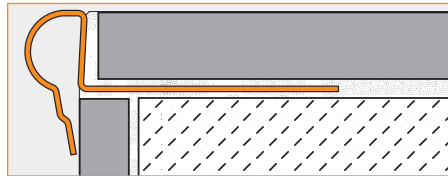

**3.4 Schluter®-TREP-FL** is a decorative stainless steel stair-nosing profile with a protruding rounded edge that can be integrated into stairs covered with tile or stone. The profile protects the front edge of stairs and adds a high degree of safety by improving the visibility of the stair edges. Schluter®-TREP-FL is suitable for use in a wide range of applications, including residential areas subjected to light foot traffic, as well as areas subjected to heavy foot traffic, such as offices or public buildings. Matching end caps are available.

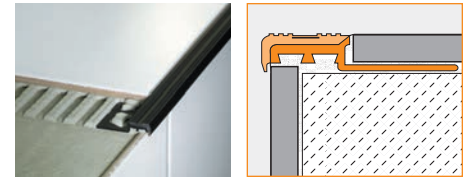

3.1 Schluter®-TREP-T/-MT/-TL

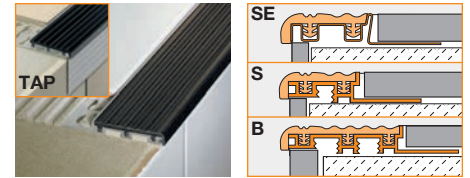

3.2 Schluter®-TREP-SE/-S/-B

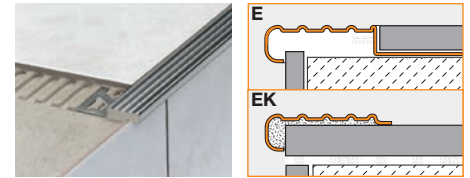

3.3 Schluter®-TREP-E/-EK

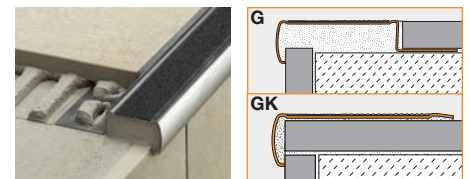

3.5 Schluter®-TREP-G/-GK

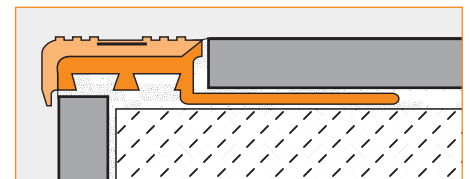

**3.1 Schluter®-TREP-T/-MT/-TL** are designed to protect tiled stair edges and provide an easily visible, slip-resistant wear surface for durable, safe, and visually appealing stair-nosing design. The profiles feature a trapezoid-perforated anchoring leg made of rigid PVC, which is secured



in the mortar bond coat beneath the tile and supports a soft, slip-resistant PVC wear surface. The slip-resistant tread is designed to increase visibility, adding a high degree of safety to stairs. Schluter®-TREP-T/-MT/-TL are intended for residential use or use in areas with similar traffic. The profiles are permanently installed in the covering and cannot be replaced when damaged by excessive wear (Note: Schluter®-TREP-SE/-S/-B offer replaceable inserts). Schluter®-TREP-T has a consistent, uniform color at the wear surface, while Schluter®-TREP-MT features a decorative brass inlay covered with a clear, soft PVC layer. Schluter®-TREP-TL features a luminescent inlay, which glows for up to 10 hours after exposure to light. This increases the visibility of stair edges in the dark and at dusk. Matching end caps are available.

### Commercial Applications

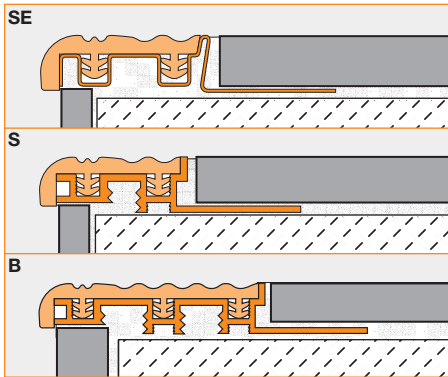

**3.2 Schluter®-TREP-SE/-S/-B** are designed to protect tiled stair edges and provide an easily visible, slip-resistant wear surface for durable, safe, and visually appealing stair-nosing design. They are suitable for use in areas subjected to heavy foot-traffic, such as offices or public buildings. The profiles feature a trapezoid-perforated anchoring leg made of stainless steel (TREP-SE) or aluminum (TREP-S and TREP-B), which is secured in the mortar bond coat beneath the tile and supports a slip-resistant thermoplastic rubber wear surface. The tread surface of Schluter®-TREP-SE/-S/-B is available in a variety of colors and can be replaced in case of damage or wear. The tread surface meets or exceeds the static coefficient of friction recommendation in the Americans with Disabilities Act (ADA), for use in applications where the risk of slipping exists (United States Testing Company, test method ASTM C 1028, .6 wet, .8 dry). Schluter®-TREP-B features a 2-1/8" (52 mm)-wide wear surface, allowing the designer to

easily produce stairs with the first and last steps marked by a 2" (50 mm)-wide strip in a contrasting color to increase visibility and safety. The leading edges of TREP-S/-SE/-B have a 5/16" (8 mm) radius. Matching end caps are available.

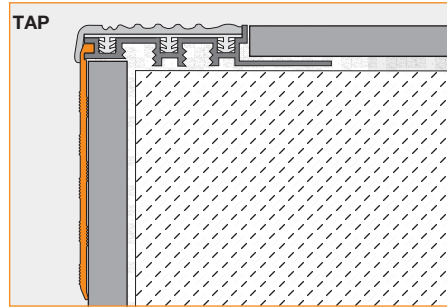

**Schluter®-TREP-TAP** is an anodized aluminum cover profile that integrates with the Schluter®-TREP-S/-B stair-nosing profiles to conceal the top of the riser.

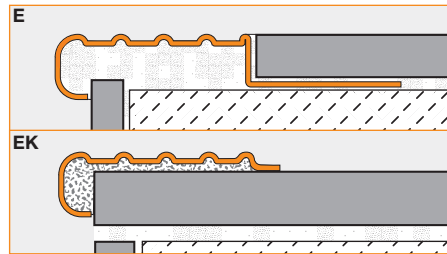

**3.3 Schluter®-TREP-E** is designed to protect tiled stair edges and provide an easily visible, slip-resistant wear surface for durable, safe, and visually appealing stair-nosing design. The profile is made of attractive and durable stainless steel, making it particularly suited for areas subjected to heavy foot traffic, such as offices or public buildings. The profile can be integrated into stairs covered with tile or natural stone, as well as into a screed or a surface coating that is a minimum 3/32" (2 mm) thick via the trapezoid-perforated anchoring leg. When integrated into screed layers, the anchoring leg of the profile must be covered with at least 9/16" (15 mm) of mortar. **Schluter®-TREP-EK** is a variant without an anchoring leg. TREP-EK is adhered to existing steps, e.g., for retrofitting over damaged edges, eliminating the need to replace the entire step. The Schluter®-TREP-E wear surface meets or exceeds the coefficient of friction recommendation in the Americans with Disabilities Act (ADA), for use in applications where the risk of slipping exists (Tile Council of North America (TCA), test method ASTM C 1028, .66 wet or dry). Matching end caps are available.

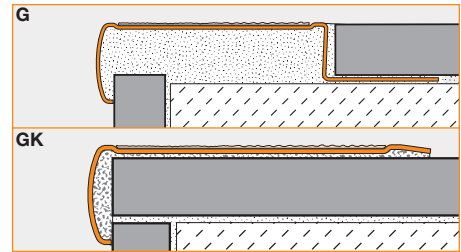

**3.5 Schluter®-TREP-G** is designed to protect tiled stair edges and provide an easily visible, slip-resistant wear surface for durable, safe, and visually appealing stair-nosing design. The profile is made of attractive and durable stainless steel with a special slip-resistant tread, making it particularly suited for areas subjected to heavy foot traffic, such as offices or public buildings. The surface features a self-adhesive, slip-resistant tread with an embedded mineral grain coating. The treads are available in a variety of colors and can be replaced in case of damage or wear. The profile can be integrated into stairs covered with tile or natural stone, as well as into a screed or surface coating. **Schluter®-TREP-GK** is a variant of the profile without an anchoring leg. TREP-GK is adhered to existing steps, e.g., for retrofitting over damaged edges, eliminating the need to replace the entire step. TREP-G is available in 1-3/16" (30 mm) and 2-5/32" (55 mm) widths, while TREP-GK is available in 1-11/32" (34 mm) and 2-21/64" (59 mm) widths. Matching end caps are available.

### Material Properties and Areas of Application

Schluter® stair-nosing profiles are resistant to most chemicals encountered in tiled environments. In special cases, the suitability of a proposed type of material must be verified based on the anticipated chemical, mechanical, and/or other stresses. Exceptions and special considerations are listed below.

**Stainless steel** profiles are roll-formed, resulting in a slightly different contour than those made of extruded aluminum. Stainless steel can sustain high mechanical stresses and is especially well suited for applications requiring resistance against chemicals and acids; for example, in the food industry, breweries, dairies, commercial kitchens, public swimming pools, and hospitals. Typically, the profiles are formed using 304 (1.4301 = V2A) stainless steel. Certain profiles, when indicated, are also formed using 316 L (1.4404 = V4A) stainless



steel, which offers even higher corrosion resistance than the 304.

**Aluminum** profiles must be tested to verify their suitability if chemical stresses are anticipated. Cementitious materials, in conjunction with moisture, become alkaline. Since aluminum is sensitive to alkaline substances, exposure to the alkali (depending on the concentration and duration of exposure) may result in corrosion (aluminum hydroxide formation). Therefore, it is important to remove mortar or grout residue from visible surfaces. In addition, ensure that the profile is solidly embedded in the setting material and that all cavities are filled to prevent the collection of alkaline water.

**Anodized aluminum** profiles feature an anodized layer that retains a uniform appearance during normal use. The surface, however, is susceptible to scratching and wear and may be damaged by grout or setting material. Therefore, these materials must be removed immediately. Otherwise, the description regarding aluminum applies. **Thermoplastic rubber** inserts are highly resistant to chemicals and can withstand chemical stresses typically encountered in tiled environments.

**PVC** treads are UV-resistant, though not permanently color-stable, in exterior applications.

**Mineral grain** coated treads are resistant to heavy mechanical stresses and can withstand chemical stresses typically encountered in tiled environments. They can be used for interior and exterior applications, except for the transparent tread that has limited UV resistance and is intended for interior use only.

## Installation

### RONDEC-STEP

1. Select RONDEC-STEP according to tile thickness. **Note:** the profile is available in two vertical leg lengths, 1-1/2" (39 mm) and 2-1/4" (57 mm), to cover the thickness of the sub-assembly.
2. Using a notched trowel, apply thin-set mortar to the area where the profile is to be placed.
3. Press the perforated anchoring leg of the profile into the mortar and align.
4. Trowel additional thin-set mortar over the perforated anchoring leg to ensure full coverage and support of the tile edges.
5. Solidly embed the tiles so that the tiled surface is flush with the top of the profile; the profile should not be higher than the tiled surface, but rather up to approx. 1/32" (1 mm) lower.

6. Set the tile to the integrated joint spacer, which ensures a uniform joint of 1/16" - 1/8" (1.5 - 3 mm).
7. Fill the joint completely with grout or setting material.
8. Work with materials and tools that will not scratch or damage sensitive surfaces. Setting materials must be removed immediately.

**Note:** Matching corners are available for RONDEC-STEP.

### TREP-FL, TREP-T/-MT/-TL, TREP-SE/-S/-B, TREP-E and TREP-G

1. Select profile size according to tile thickness.
2. Install riser tile flush with the stair tread surface.
3. Using a notched trowel, apply thin-set mortar along edge area above riser.
4. Fill cavities on the underside of the profile with thin-set mortar (Exception: does not apply to TREP-FL).
5. Press the trapezoid-perforated anchoring leg of the profile into the thin-set mortar, making sure the front edge of the support section is aligned flush with the riser tile (Exception: TREP-E, TREP-FL and TREP-G are installed such that the front edge of the profile overlaps the riser tile). Full coverage must be obtained at the edge area to ensure support of the profile.
6. Trowel additional thin-set mortar over the anchoring leg and the stair tread surface to ensure full coverage and support of the tile edges.
7. Solidly embed the tread tiles so that the tiled surface is flush with the top of the profile.
8. A joint of approx. 1/16" - 1/8" (1.5 mm - 3 mm) should be left between the tile and the profile.
9. Fill joint completely with grout or setting material.

**Notes:** When Schluter®-TREP-E or TREP-G is integrated into screed layers, the profile must be completely embedded in the mortar. The trapezoid-perforated anchoring leg must be covered with at least 9/16" (15 mm) of mortar.

When using surface coatings, the coating must be a minimum 3/32" (2 mm) thick. Schluter®-TREP-E or TREP-G is adhered to the edge of the stair tread and adjusted in such a way that the front edge of the profile is flush with the riser. The trapezoid-perforated anchoring leg is covered completely with the surface coating, so that

the finished surface is flush with the profile. When using Schluter®-TREP-TAP, apply Schluter®-KERDI-FIX or similar adhesive to the riser and insert the cover profile in the support section of Schluter®-TREP-S/-B prior to installing the stair-nosing profile. TREP-TAP should not be used where it can extend past the bottom of the riser.

### TREP-EK and TREP-GK

1. Clean the stair nosings and repair damaged areas if applicable.
2. Clean or degrease the underside of the profile.
3. Adhere the profile by fully embedding it into a suitable adhesive (e.g., epoxy resin or Schluter®-KERDI-FIX, depending on the substrate).

**Note:** The upper profile edge of TREP-EK is approximately 3/32" (2.5 mm) higher than the stair covering, while the upper profile edge of TREP-GK is approximately 1/16" (1.5 mm) higher than the stair covering.

## Maintenance

Schluter® stair-nosing profiles require no special maintenance or care and are resistant to mold and fungi. Clean profiles using common household cleaning agents.

**Stainless steel** surfaces exposed to the environment or aggressive substances should be cleaned periodically using a mild household cleaner. Regular cleaning maintains the neat appearance of stainless steel and reduces the risk of corrosion. All cleaning agents must be free of hydrochloric and hydrofluoric acid. Stainless steel surfaces develop a sheen when treated with a chrome-polishing agent.

Oxidation films on **aluminum** may be removed with a conventional polishing agent, but will form again.

In the case of **anodized aluminum**, do not use abrasive cleaning agents. Damage to the anodized layer can be repaired by applying varnish.

The treads of Schluter®-TREP-SE/-S/-B/-G/-GK can be replaced in case of damage or wear.



Product Item Numbers

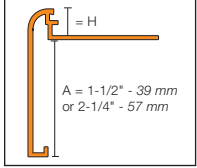
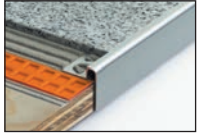

**2.8 Schluter®-RONDEC-STEP**

H = mm - in.	Item No.					
	Satin anodized aluminum (AE)	Brushed chrome anodized aluminum (ACGB)	Satin nickel anodized aluminum (AT)	Brushed nickel anodized aluminum (ATGB)	Satin copper/bronze anodized aluminum (AK)	Brushed copper/bronze anodized aluminum (AKGB)
<b>A: 39 mm - 1-1/2"</b>						
8 - 5/16	RS 80 AE 39	RS 80 ACGB 39	RS 80 AT 39	RS 80 ATGB 39	RS 80 AK 39	RS 80 AKGB 39
10 - 3/8	RS 100 AE 39	RS 100 ACGB 39	RS 100 AT 39	RS 100 ATGB 39	RS 100 AK 39	RS 100 AKGB 39
12.5 - 1/2	RS 125 AE 39	RS 125 ACGB 39	RS 125 AT 39	RS 125 ATGB 39	RS 125 AK 39	RS 125 AKGB 39
<b>A: 57 mm - 2-1/4"</b>						
8 - 5/16	RS 80 AE 57	RS 80 ACGB 57	RS 80 AT 57	-	RS 80 AK 57	RS 80 AKGB 57
10 - 3/8	RS 100 AE 57	RS 100 ACGB 57	RS 100 AT 57	-	RS 100 AK 57	RS 100 AKGB 57
12.5 - 1/2	RS 125 AE 57	RS 125 ACGB 57	RS 125 AT 57	-	RS 125 AK 57	RS 125 AKGB 57

H = mm - in.	Item No.		
	Satin brass anodized aluminum (AM)	Brushed brass anodized aluminum (AMGB)	Brushed antique bronze anodized aluminum (ABGB)
<b>A: 39 mm - 1-1/2"</b>			
8 - 5/16	-	RS 80 AMGB 39	RS 80 ABGB 39
10 - 3/8	-	RS 100 AMGB 39	RS 100 ABGB 39
12.5 - 1/2	-	RS 125 AMGB 39	RS 125 ABGB 39
<b>A: 57 mm - 2-1/4"</b>			
8 - 5/16	RS 80 AM 57	RS 80 AMGB 57	-
10 - 3/8	RS 100 AM 57	RS 100 AMGB 57	-
12.5 - 1/2	RS 125 AM 57	RS 125 AMGB 57	-

Length supplied: 8' 2-1/2" – 2.50 m

Accessories	Item No.
Outside corner, 90°	E 90 <i>profile item number*</i>
Outside corner, 135°	E 135 <i>profile item number*</i>
Inside corner, 90°	I 90 <i>profile item number*</i>
Inside corner, 135°	I 135 <i>profile item number*</i>

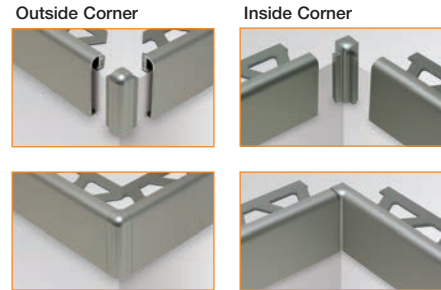

**How to order corners:**

\*To complete the item number for corners, add the corresponding *profile item number* (e.g., E 90 **RS 80 ACGB 39**).

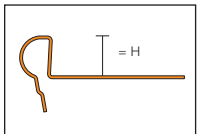

**3.4 Schluter®-TREP-FL**

H = mm - in.	Item No.	
	Stainless steel 304 (1.4301 = V2A) (E)	Brushed stainless steel 304 (1.4301 = V2A) (EB)
<b>Length supplied: 4' 11" – 1.5 m</b>		
9 - 11/32	FL 90 E / 150	FL 90 EB / 150
11 - 7/16	FL 110 E / 150	FL 110 EB / 150
12.5 - 1/2	FL 125 E / 150	FL 125 EB / 150
<b>Length supplied: 8' 2-1/2" – 2.5 m</b>		
9 - 11/32	FL 90 E	FL 90 EB
11 - 7/16	FL 110 E	FL 110 EB
12.5 - 1/2	FL 125 E	FL 125 EB

**Accessories**

Accessories	Item No.
End cap	E/ FLEB



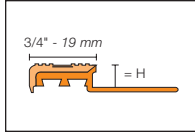
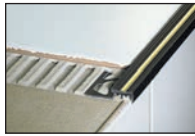

**3.1 Schluter®-TREP-T**

H = mm - in.	Item No.	
	Without inlay	
8 - 5/16	T	<i>color*</i> 8
11 - 7/16	T	<i>color*</i> 11

Length supplied: 8' 2-1/2" - 2.5 m

Accessories	Item No.
End cap	EKT / <i>color*</i>



**3.1 Schluter®-TREP-MT**

H = mm - in.	Item No.	
	Brass inlay	
8 - 5/16	MT	<i>color*</i> 8
11 - 7/16	MT	<i>color*</i> 11

**\*Color Codes (-T/-MT)**



To complete the item number, add the *color* code (e.g., T **HB** 8).

**3.1 Schluter®-TREP-TL**

H = mm - in.	Item No.	
	Luminescent inlay	
8 - 5/16	T	<i>color*</i> 8 L
11 - 7/16	T	<i>color*</i> 11 L

**\*Color Codes (-TL)**



To complete the item number, add the *color* code (e.g., T **SB** 8 L).

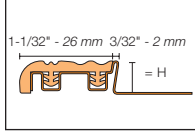

**3.2 Schluter®-TREP-SE**

H = mm - in.	Item No.	
	Stainless steel support with thermoplastic rubber insert	Stainless steel support section 304 (1.4301 = V2A)
8 - 5/16	<i>color*</i> 8 SE / 150	TES 8 / 150
10 - 3/8	<i>color*</i> 10 SE / 150	TES 10 / 150
12.5 - 1/2	<i>color*</i> 12 SE / 150	TES 12 / 150

Length supplied: 4' 11" - 1.5 m

Length supplied: 8' 2-1/2" - 2.5 m		
8 - 5/16	<i>color*</i> 8 SE	TES 8
10 - 3/8	<i>color*</i> 10 SE	TES 10
12.5 - 1/2	<i>color*</i> 12 SE	TES 12

Accessories	Item No.
End cap	E 26 / <i>color*</i>



**3.2 Schluter®-TREP-S**

Length = m - ft.	Item No.	
	Replacement thermoplastic rubber insert	
2.5 - 8' - 2-1/2"	PE 26 /	<i>color*</i>
3 - 10'	PE 26 /	<i>color*</i> / 300
15 - 50'	PE 26 /	<i>color*</i> / 50

**\*Color Codes**



\* To complete the item number, add the *color* code (e.g., **G** 10 SE).

Note: Radius of leading edge = 5/16" - 8 mm.

Note: Radius of leading edge = 5/16" - 8 mm.

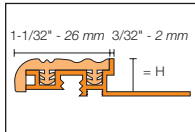

**3.2 Schluter®-TREP-S**

H = mm - in.	Item No.	
	Aluminum support with thermoplastic rubber insert	Aluminum support section
8 - 5/16	<i>color*</i> 8 SE / 150	TAS 8 / 150
10 - 3/8	<i>color*</i> 10 SE / 150	TAS 10 / 150
12.5 - 1/2	<i>color*</i> 12 SE / 150	TAS 12 / 150

Length supplied: 4' 11" - 1.5 m

Length supplied: 8' 2-1/2" - 2.5 m		
8 - 5/16	<i>color*</i> 8 SE	TAS 8
10 - 3/8	<i>color*</i> 10 SE	TAS 10
12.5 - 1/2	<i>color*</i> 12 SE	TAS 12

Accessories	Item No.
End cap	E 26 / <i>color*</i>



**3.2 Schluter®-TREP-S**

Length = m - ft.	Item No.	
	Replacement thermoplastic rubber insert	
2.5 - 8' - 2-1/2"	PEA 26 /	<i>color*</i>
3 - 10'	PEA 26 /	<i>color*</i> / 300
15 - 50'	PEA 26 /	<i>color*</i> / 50

**\*Color Codes**

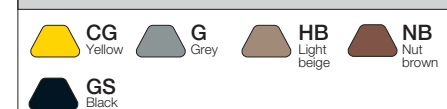

\* To complete the item number, add the *color* code (e.g., **G** 10 S).

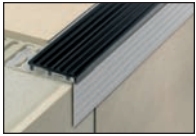

### 3.2 Schluter®-TREP-TAP

Item No.

Satin anodized aluminum (AE)

Length supplied: 8' 2-1/2" — 2.5 m

TAPR 61 AE

Length supplied: 4' 11" — 1.5 m

TAPR 61 AE / 150

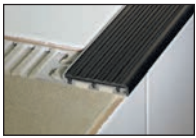
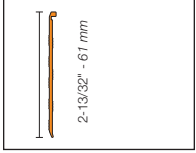

### 3.2 Schluter®-TREP-B

Item No.

H =  
mm - in.

Aluminum support with thermoplastic rubber insert  
Aluminum support section

Length supplied: 8' 2-1/2" — 2.5 m

8 - 5/16	color* 8 B	TAB 8
10 - 3/8	color* 10 B	TAB 10
12.5 - 1/2	color* 12 B	TAB 12
15 - 9/16	color* 15 B	TAB 15
25 - 1	color* 25 B	TAB 25

Length supplied: 4' 11" — 1.5 m

8 - 5/16	color* 8 B / 150	TAB 8 / 150
10 - 3/8	color* 10 B / 150	TAB 10 / 150
12.5 - 1/2	color* 12 B / 150	TAB 12 / 150
15 - 9/16	color* 15 B / 150	TAB 15 / 150
25 - 1	color* 25 B / 150	TAB 25 / 150

Length =  
m - ft.

Item No.

Replacement thermoplastic rubber insert

2.5 - 8' - 2-1/2"	PEA 52 / color*
3 - 10'	PEA 52 / color* / 300
15 - 50'	PEA 52 / color* / 50

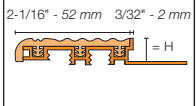

Note: Radius of leading edge = 5/16" - 8 mm.

#### \*Color Codes



\* To complete the item number, add the color code (e.g., G 10 B).

Accessories

Item No.

End cap

E 52 / color\*



### 3.3 Schluter®-TREP-E

Item No.

H =  
mm - in.

Stainless steel  
304 (1.4301 = V2A)

Length supplied: 8' 2-1/2" — 2.5 m

2 - 3/32	TE 20
5 - 3/16	TE 50
8 - 5/16	TE 80
11 - 7/16	TE 110
16 - 5/8	TE 160
25 - 1	TE 250

Length supplied: 4' 11" — 1.5 m

2 - 3/32	TE 20 / 150
5 - 3/16	TE 50 / 150
8 - 5/16	TE 80 / 150
11 - 7/16	TE 110 / 150
16 - 5/8	TE 160 / 150
25 - 1	TE 250 / 150

Accessories

Item No.

End cap

E/TE

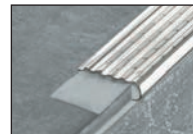

### 3.3 Schluter®-TREP-EK

Item No.

H =  
mm - in.

Stainless steel  
304 (1.4301 = V2A)

Length supplied: 8' 2-1/2" — 2.5 m

TEK

Length supplied: 4' 11" — 1.5 m

TEK / 150

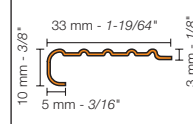

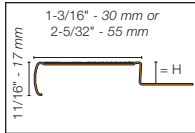

### 3.3 Schluter®-TREP-G-S

H = mm - in.	Item No.
	Stainless steel support with non-slip tread (30 mm - 1-3/16")
<b>Length supplied: 8' 2-1/2" - 2.5 m</b>	
9 - 11/32	GS EB 90 + <i>color*</i>
11 - 7/16	GS EB 110 + <i>color*</i>
13 - 33/64	GS EB 130 + <i>color*</i>
15 - 9/16	GS EB 150 + <i>color*</i>
<b>Length supplied: 4' 11" - 1.5 m</b>	
9 - 11/32	GS EB 90 + <i>color*</i> / 150
11 - 7/16	GS EB 110 + <i>color*</i> / 150
13 - 33/64	GS EB 130 + <i>color*</i> / 150
15 - 9/16	GS EB 150 + <i>color*</i> / 150

### 3.3 Schluter®-TREP-G-B

H = mm - in.	Item No.
	Stainless steel support with non-slip tread (55 mm - 2-5/32")
<b>Length supplied: 8' 2-1/2" - 2.5 m</b>	
9 - 11/32	GB EB 90 + <i>color*</i>
11 - 7/16	GB EB 110 + <i>color*</i>
13 - 33/64	GB EB 130 + <i>color*</i>
15 - 9/16	GB EB 150 + <i>color*</i>
<b>Length supplied: 4' 11" - 1.5 m</b>	
9 - 11/32	GB EB 90 + <i>color*</i> / 150
11 - 7/16	GB EB 110 + <i>color*</i> / 150
13 - 33/64	GB EB 130 + <i>color*</i> / 150
15 - 9/16	GB EB 150 + <i>color*</i> / 150

Length = m - ft.	Item No.
18.3 - 60' 1/32"	GS KB 183 / <i>color*</i>

Accessories	Item No.
End cap	E/GS EB

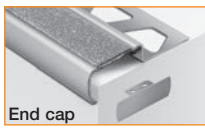

**\*Color Codes**

CG Yellow   
 GS Black   
 NB Nut Brown   
 T Transparent

To complete the item number, add the *color\** code (e.g., GS EB 90 *GS*).

Length = m - ft.	Item No.
18.3 - 60' 1/32"	GB KB 183 / <i>color*</i>

Accessories	Item No.
End cap	E/GB EB



**\*Color Codes**

CG Yellow   
 GS Black   
 NB Nut Brown   
 T Transparent

To complete the item number, add the *color\** code (e.g., GB EB 90 *GS*).

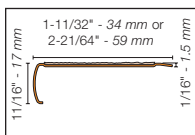

### 3.3 Schluter®-TREP-GK-S

Item No.
Brushed stainless steel support with non-slip tread (34 mm - 1-11/32")
<b>Length supplied: 8' 2-1/2" - 2.5 m</b>
GS EBK + <i>color*</i>
<b>Length supplied: 4' 11" - 1.5 m</b>
GS EBK + <i>color*</i> / 150

Item No.
Replacement tread
<b>Length supplied: 60' 1/32" - 18.3 m</b>
GS KB 183 + <i>color*</i>

### 3.3 Schluter®-TREP-GK-B

Item No.
Brushed stainless steel support with non-slip tread (59 mm - 2-21/64")
<b>Length supplied: 8' 2-1/2" - 2.5 m</b>
GB EBK + <i>color*</i>
<b>Length supplied: 4' 11" - 1.5 m</b>
GB EBK + <i>color*</i> / 150

Item No.
Replacement tread
<b>Length supplied: 60' 1/32" - 18.3 m</b>
GB KB 183 + <i>color*</i>



**2.8 Schluter®-RONDEC-STEP**, in satin anodized aluminum, installed to effectively hide and protect stair tread edges in a residential application.

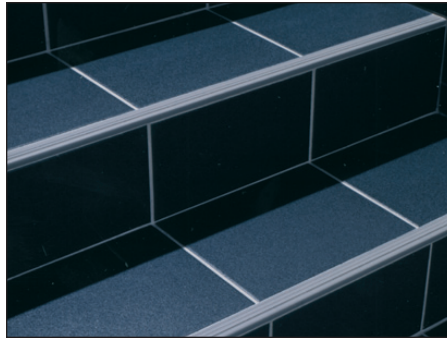

**3.2 Schluter®-TREP-S**, in grey (left) and nut brown (right), installed to finish and protect tiled stair edges in areas subjected to heavy foot traffic. The slip-resistant tread is available in various colors to provide contrast and improve visibility and can be replaced in cases of damage or excessive wear.

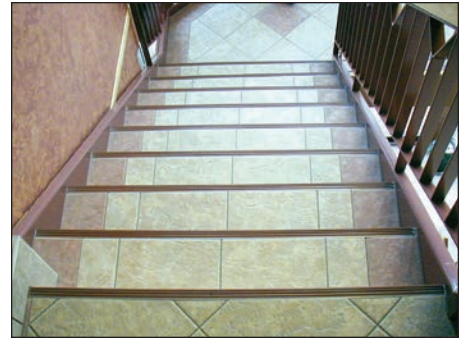

**3.3 Schluter®-TREP-E**, in stainless steel, installed to provide a durable, slip-resistant stair tread edge and accentuate the design elements of an office building.



PROFILE OF INNOVATION

**Schluter Systems L.P.** • 194 Pleasant Ridge Road, Plattsburgh, NY 12901-5841  
Tel.: 1-800-472-4588 • Fax: 1-800-477-9783 • e-mail: info@schluter.com

**Schluter Systems (Canada) Inc.** • 21100 ch. Ste-Marie, Ste-Anne-de-Bellevue, QC H9X 3Y8  
Tel.: 1-800-667-8746 • Fax: 1-877-667-2410 • e-mail: info@schluter.com

[www.schluter.com](http://www.schluter.com)