

prestige

Fully Condensing Water Boiler



TriangleTube

Engineering Submittal

Prestige Solo 250



Prestige Solo Features

- Light weight construction for wall mounting
- Approved for zero clearance to combustibles
- 3" PVC, CPVC, PP, or AL29-4C venting up to 60 equivalent feet
- 4" PVC, CPVC, PP or AL29-4C venting up to 80 equivalent feet
- Limited 10 year warranty on heat exchanger

Approvals

- 96% AFUE Efficiency
- ENERGY STAR Qualified
- ANSI Z21.13 and CSA 4.9 Boiler Standards Compliance
- ASME Boiler Certification – ASME "H" Stamp
- Low NOx operation exceeding SCQMD 2012 regulations

Stainless Steel Fire Tube Heat Exchanger

- 439 Stainless Steel heat exchanger construction
- Low pressure drop minimizes circulator size
- High water content provides stable temperature control
- Self cleaning flue ways reduce maintenance
- Suitable for use with propylene glycol up to 50% concentration.

TriMax Control System

- Graphical display with 6 navigation buttons
- EZ Setup allows quick and easy boiler settings adjustment
- Logging function records sensor readings for system optimization and troubleshooting
- Lockout screen includes a text description with basic troubleshooting information
- Outdoor temperature reset to maximize efficiency
- Two space heating call inputs with independent outdoor reset curves
- Domestic hot water priority with optional time-out
- Integrated cascade control for up to 6 Prestige boilers
- 0-10 VDC Modulation input
- Modbus building management system (BMS) interface
- Warm weather shutdown option
- Optional boiler freeze protection
- Capability to control up to 4 circulators
 - Central heating (CH) circulator
 - Domestic hot water (DHW) circulator
 - Auxiliary boiler circulator
 - System circulator

Standard Equipment

- Stainless steel premix burner
- Direct spark ignition with variable speed blower
- Full modulation from 25% to rated input
- Automatic air vent
- ASME 30 PSI pressure relief valve
- Integrated pressure and temperature gauge
- Outdoor temperature sensor
- Automatic low water cutoff feature
- High temperature limit safety control
- Line voltage terminal strip with individual fuses
- Low voltage terminal strip with removable jumpers for manual or automatic reset limits
- Swing down control panel for easy access and servicing
- Alarm contact
- Polypropylene condensate pan and internal flue pipe
- Polypropylene vent/air connections with test ports

Project / Location: _____ Date: _____

Consulting Engineer / Architect: _____

Mechanical Contractor: _____

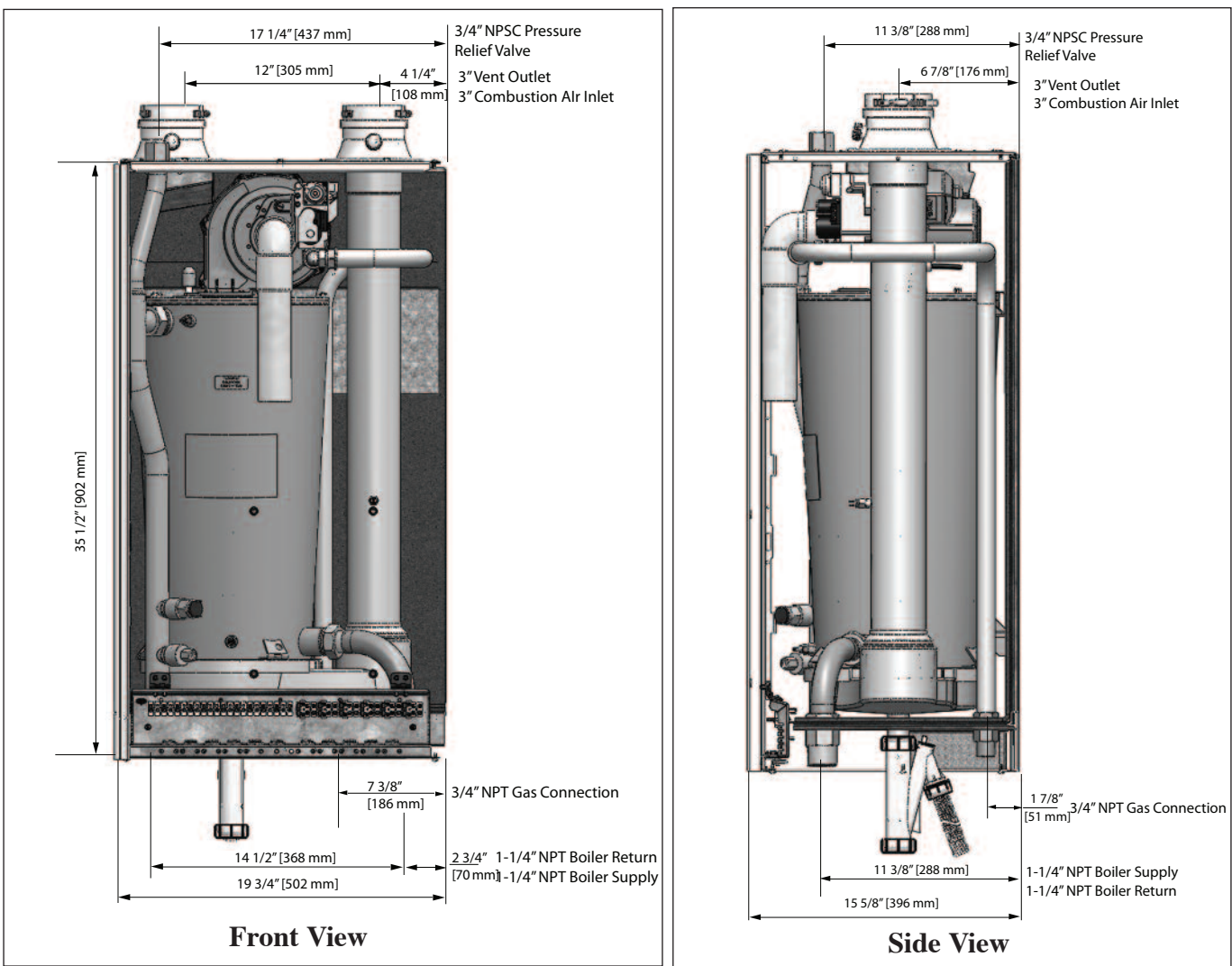

Boiler Specifications

Model	Fuel	Input Modulation (MBH)	AFUE	DOE Heating Capacity MBH	Net I=B=R	Boiler Water Volume (gal)	Supply Return Connection	Gas Connection	Vent/Air Diameter	Weight Lbs
PT250	Natural or Propane Gas	65 - 245	96%	223	194	4.1	1 1/4"	3/4"	3"	142

Pressure Drop Curve with Grundfos Circulators

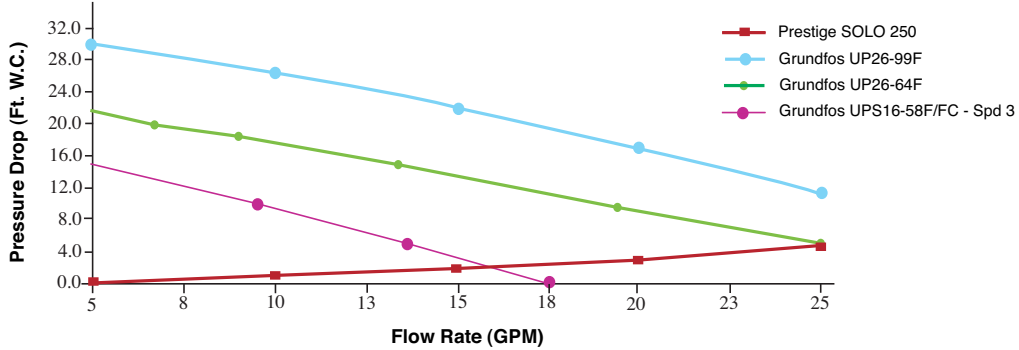

Delta T	GPM	Available System Head (Feet)		
		UPS15-58F/FC	UP26-64F	UP26-99F
20	19.4	----	6.9	14.9
30	12.9	4.5	13.5	22.5
40	9.7	8.8	16.5	25.8